

Matrilineal genetic structure of the brown bear population in Finland

Urmas Saarma^{1,2,4} and Ilpo Kojola^{3,5}

¹Department of Integrative Zoology, Institute of Zoology and Hydrobiology, University of Tartu, Vanemuise 46, 51014, Tartu, Estonia

²Estonian Biocentre, Riia 23, 51010, Tartu, Estonia

³Finnish Game and Fisheries Research Institute, Oulu Game and Fisheries Research, Tutkijatit 2A, FIN-90570, Oulu, Finland

Abstract: We analyzed phylogenetic relationships of brown bear (*Ursus arctos*) maternal lineages in Finland using nucleotide sequences of the mitochondrial control region of 135 individuals. A total of 14 haplotypes, which belong to 2 haplogroups, were characterized. Haplogroup I is spread across the entire bear range, whereas haplogroup D is restricted to the southeastern part of the country. Most unconventional was the concentration of haplotype C in a small territory in central Finland, which is explained by the natal philopatry of bears that descended from one or more translocated females. Analysis of Finnish brown bear haplotypes together with 15 European eastern lineage haplotypes revealed that the Romanian–Slovakian region was probably an important refuge (or route) for recolonization of Finland by brown bears after the last ice age.

Key words: brown bear, control region, Finland, ice age, mtDNA, phylogeography, recolonization, *Ursus arctos*

Ursus 18(1):30–37 (2007)

Brown bear (*Ursus arctos*) populations in central and southern Europe are mostly fragmentary as compared to the situation a few centuries ago. The species has been driven to extinction in several countries in Europe and human activities have been largely responsible for these trends (Servheen 1990). The populations of brown bears of northern Europe are currently among the most viable and numerous in Europe, although some populations have passed through severe bottlenecks (Zedrosser et al. 2001). Timely management efforts have allowed populations to increase and expand. Approximately 40,000 bears are thought to exist in northeastern Europe. The core of the northeastern European bear population is in the European part of Russia with approximately 36,000 bears (Zedrosser et al. 2001), whereas populations of other countries are considerably smaller. Today, Finland has an estimated 800–850 bears (Kojola and Määttä 2004), Estonia 250–500 (Valdmann et al. 2001), and Sweden about 2,200 (J. Swenson, Norwegian University of Life Sciences, Ås, Norway, personal communication, 2005). There are also about 20–40 bears in Latvia, 250 in Belarus, and 8–21 in Norway (Zedrosser et al.

2001). Several northeastern European brown bear populations, including the Finnish, have retained their viability due to immigration from Russia (Pulliainen 1990, 1997).

According to current knowledge, sequences of the mtDNA control region divide the European population of *U. arctos* into 2 major lineages: eastern and western (Taberlet and Bouvet 1994, Kohn et al. 1995, Kohn and Knauer 1998, but see Hofreiter et al. 2004). The western lineage holds bear populations mainly of western, southern, and central Europe (Spain, France, Italy, Greece, Slovenia, Croatia, Bulgaria, Romania, but also southern Sweden). The western lineage appears to have colonized most of Europe from an Iberian refuge. The Eastern lineage is represented by bears of eastern, central, and northern Europe, such as Slovakia, Finland, Estonia, northern Sweden, Russia, and Romania, and their ancestors recolonized northern Europe from the putative Caucasian–Carpathian refuge (Taberlet et al. 1998, Hewitt 2000). These expansions met in central Sweden after the recession of the Scandinavian ice-cap and formed a hybrid zone (Taberlet et al. 1995).

The brown bear population in Finland is connected to the Russian and Swedish bear populations

⁴Urmass.Saarma@ut.ee ⁵Ilpo.Kojola@rktl.fi



Fig. 1. Schematic map of Fennoscandia and Karelia (Russia). Finland is in grey.

(Fig. 1) via habitat corridors (Kojola et al. 2003; J. Swenson, personal communication, 2005). The size of the Finnish bear population was around 1,400–1,500 individuals in the beginning of the 19th century (I. Kojola and A. Ermala, Finnish Game and Fisheries Research Institute, Oulu Game and Fisheries Research, Oulu, Finland, unpublished data). A major decline in bear numbers and distribution took place during the second half of the 19th century (Palmen 1913). This was a result of government-supported destruction of large carnivore populations, and bears were exterminated from the south, southwest and west of Finland by the 1900s. The remnants of the bear population were restricted to the northern and eastern parts of the country. The bear population was at its lowest in the beginning of the 20th century, but by the late 1960s, had begun to increase (from 150 in 1970 to 450 in 1985) and gradually extended its range toward the western and southern territories of Finland (Pulliainen 1990). The first litters were detected in central Finland in the late 1980s, and in the western and southern parts in the early 1990s (Kojola and Laitala 2000).

Today, the Finnish bear population has spread over most of the country except Åland Islands in the west and the open, low mountain area in the Utsjoki district in the north (Nyholm and Nyholm 1999). Most of the bears in Finland live along the border with Russia. The Russian part of Karelia is known to be inhabited by a stable bear population of over 3,000 individuals (Danilov 2003). Records made by the frontier guard detachment in Finland have demonstrated that Finland has been receiving

a considerable number of immigrants from the high-density Karelian population, which to a large extent explains the population growth and range expansion in spite of relatively high human harvest rates (Pulliainen 1997).

To reconstruct the history of the brown bear population in Finland, analysis of maternal lineages could be most informative, as brown bear females are philopatric. The mitochondrial genome is a valuable genetic entity, specific to maternal lineage. Here, we characterize the matrilineal genetic structure and female-driven history of the brown bear population in Finland by analyzing the mitochondrial control region.

Methods

Muscle and liver samples (Table 1) from 135 brown bears, shot legally during sport hunting during 1999–2003, came from a frozen tissue collection kept by the Finnish Game and Fisheries Research Institute at Taivalkoski, Finland. All samples were stored at -80°C before use. Total genomic DNA was extracted using the QIAamp DNA Mini Kit (Qiagen GmbH, Hilden, Germany) or the High Pure PCR Template Preparation Kit (Roche Diagnostics GmbH, Mannheim, Germany), following the manufacturer's protocols.

A 631 base-pair (bp) fragment of the mitochondrial genome (comprising the 3' end of the cytochrome b gene, positions 16311–16445; tRNA-Thr, positions 16446–16515; tRNA-Pro, positions 16516–16580; and 5' portion of the control region, positions 16581–16942) was polymerase chain reaction (PCR)-amplified with primers L15774 and H16498 (Shields and Kocher 1991). L15774 primer binds to mtDNA sequence 16311–16333 and H16498 to 16923–16942 (numbers are according to our reference sequence AF303110 in GenBank [Benson et al. 2007], which is a complete mtDNA sequence of a brown bear). Twenty to 80 nanograms of purified genomic DNA and 4 picomoles of primers were used for polymerase chain reaction. PCR was performed in a total volume of 20 μl . Cycling parameters were 5 min denaturing at 94°C , followed by 35 cycles of 1 min at 94°C , 1 min at 55°C , and 1 min at 72°C with 1 unit of Platinum Taq DNA polymerase (Invitrogen, Basel, Switzerland), 0.2 mM dNTP and 1.5 mM MgCl_2 . The PCR product was purified with shrimp alkaline phosphatase/exonuclease I (USB, Cleveland, USA) treatment. One unit of both enzymes

Table 1. Brown bear mtDNA haplotype and haplogroup codes, the number of individuals found for each haplotype, their locations, and sequence accession numbers in GenBank (Benson et al. 2007) for brown bear DNA analyzed.

Haplotype code	Haplogroup code	Individuals	Individuals northern Finland	Individuals southern Finland	GenBank reference
A	D	2	—	2	AY331262
C	D	7	1	6	AY331264
D	D	27	—	27	AY331265
N	D	1	—	1	AY331275
O	D	1	—	1	AY331276
P	D	1	—	1	AY331277
Q	D	1	—	1	AY331278
F	I	1	1	—	AY331267
I	I	87	40	47	AY331270
J	I	3	1	2	AY331271
K	I	1	—	1	AY331272
R	I	1	—	1	AY331279
S	I	1	1	—	AY331280
T	I	1	1	—	AY331281
Total		135	45	90	

were added to 10 µl of PCR reaction and incubated for 30 min at 37°C, followed by a 15 min inactivation at 80°C.

DNA cycle sequencing was performed using the DYEnamic ET Terminator Cycle Sequencing Kit (Amersham Biosciences, Uppsala, Sweden). Thirty-three cycles (15 sec at 95°C, 15 sec at 50°C, and 1 min at 60°C) were performed in a total volume of 10 µl. Sequences were resolved on an ABI PRISM 377 automated DNA sequencer (Applied Biosystems, Foster City, USA). To obtain unequivocal sequences, both chains of DNA were sequenced using primers L15774 or H16498. Consensus sequences were created with program Consed (Gordon et al. 1998).

Sequences were aligned with the Clustal W (Thompson et al. 1994), using BioEdit (Hall 1999) and were manually proofed. All mtDNA haplotypes were submitted to the GenBank (Table 1). Hypotheses of demographic expansion were tested using Fu's Fs, Fu and Li's F, and Tajima's D statistic, and a mismatch distribution analysis was performed using the DnaSP 4.10.7 software package (Rozas et al. 2003).

To evaluate the phylogenetic position of Finnish brown bears in the context of other European bear populations from the eastern lineage, 15 mtDNA control region haplotypes were included from GenBank. Due to shorter sequences from GenBank, this analysis is based on 206 bp fragment of the mtDNA control region (covering 5' portion of the mtDNA control region, positions 16589–16789). A median joining network was calculated with Netw4108 computer software using default settings

(Bandelt et al. 1999). According to Lambert et al. (2002:2271) "Median networks provide a useful representation of intraspecies data that are characterized by a small number of base substitutions between sequences and high levels of homoplasy (parallel or convergent mutations). In contrast to standard tree representations, where only the tips of the tree are labeled, nodes in a median network represent either sampled haplotypes or inferred intermediates."

Results

Among 135 sequences, 14 mtDNA haplotypes were found (Table 1). Sequences of 388 bp in length were used (corresponding to positions 16407–16789 of AF30311, covering the 3' end of the cytochrome b sequence; positions 16407–16445; tRNA-Thr, positions 16446–16515; tRNA-Pro, positions 16516–16580; and 5' portion of the control region, positions 16581–16789). Thirteen nucleotide positions were variable, including 7 transitions, 4 transversions, and 32 indels (all indels were in the pyrimidine tract). Haplotypes I and D form the core of 2 haplogroups (Figs 2, 3): the most abundant haplogroup I (70% of the total bear number) consists of haplotypes F, I, J, K, R, S, and T, and the second and smaller (30%) includes haplotypes A, C, D, E, N, O, and P. Both haplogroups form star-like structures (Fig. 4).

Haplotype I was the most abundant (64.4% of all bears analyzed), and bears with this haplotype were found over a vast part of the bear habitat in Finland,

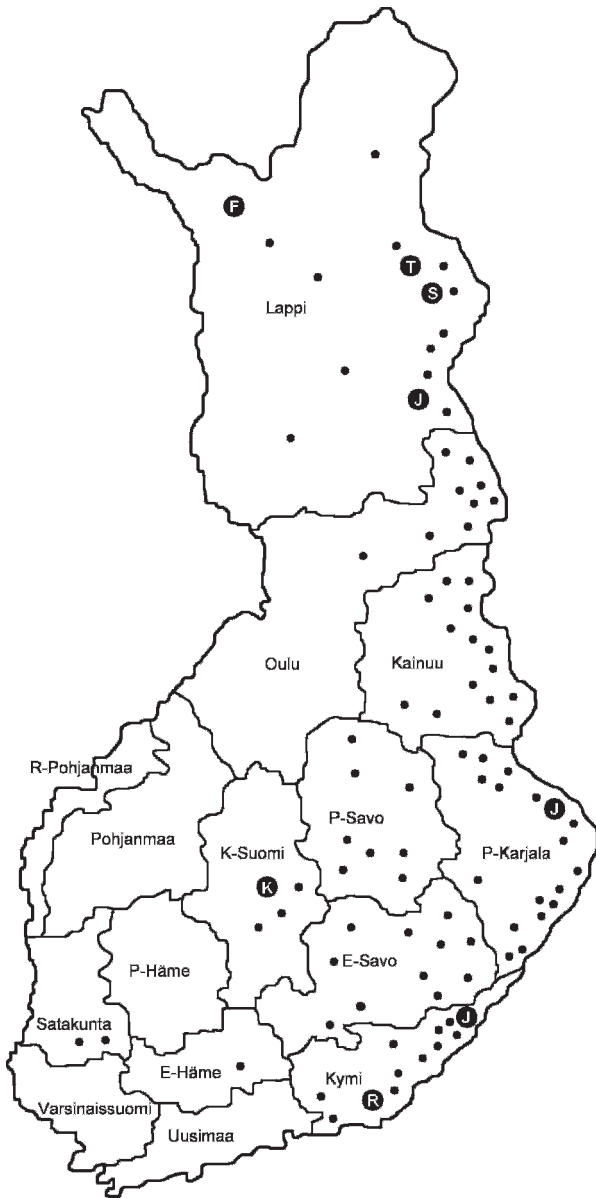

Fig. 2. Locations of brown bear mtDNA haplotypes of the haplogroup I in Finland. Dots represent the distribution of bears that belong to haplogroup I; other haplotypes are shown in white capital letters in black circles.

also reaching the western and southern parts of the country. Haplotype D was also numerous (20%), but its range was limited to southeastern Finland. Other haplotypes were rare or unique: 9 were represented by a single individual (Table 1) and haplotypes F and S were found only in Northern Finland. Several rare or unique haplotypes were also recorded at the

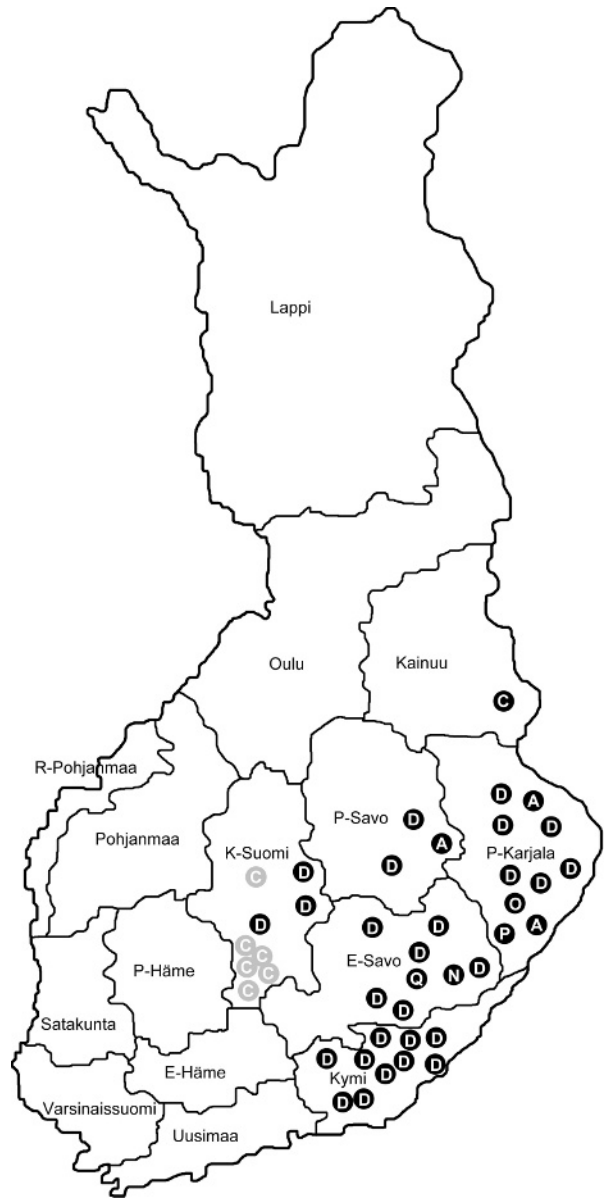

Fig. 3. Locations of brown bear mtDNA haplotypes of the haplogroup D in Finland. Haplotypes are shown in white capital letters inside black circles. Haplotype C (the translocated genotype) is shown in gray circles.

eastern border (N, O, P, Q, R, and T). Six bears with haplotype C were found exclusively in the central part of Finland, at Multia and Kyyjärvi and a single a single case at the eastern border (Fig. 3).

Hypotheses of demographic expansion were tested using Tajima's D and Fu and Li's F and Fu's F_s statistics (Table 2). Results were fully consistent with

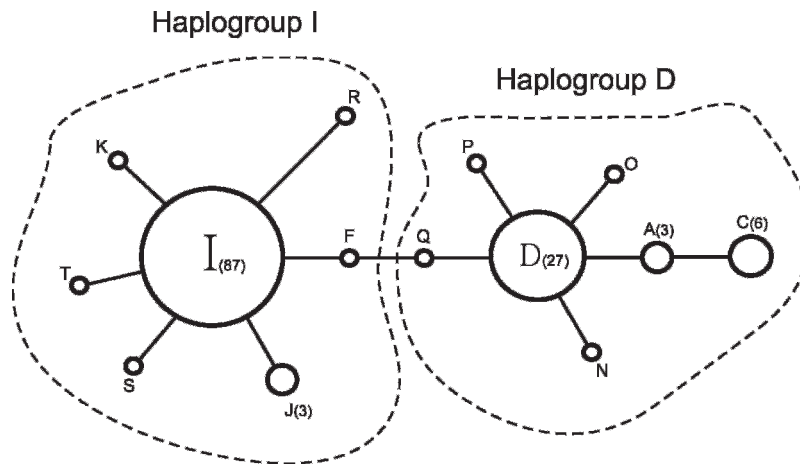

Fig. 4. Minimum spanning network, illustrating the relationships of brown bear mtDNA haplotypes in Finland. The number of individuals is given in parentheses (if more than a single representative); difference in circle size indicates the frequency of the haplotype.

population expansion of haplogroup I, whereas the others received support from part of the statistics (whole population) or no support (haplogroup D). The unimodal distribution of pairwise differences among haplotypes within haplogroup I (whole population and haplogroup D exhibited bimodal distribution) and nonsignificant raggedness index, obtained from mismatch distribution analysis (data not shown), are consistent with a model of sudden expansion of this haplogroup (Harpending 1994).

Analysis of Finnish brown bear haplotypes together with other European haplotypes from the eastern lineage revealed that Finnish haplotypes are scattered throughout the network and in 4 cases shared identical haplotypes with bears from other countries (Fig. 5).

Discussion

In Finland, most of the haplotypic diversity of the brown bear population is concentrated in the border zone between Finland and Russia. The entire border

between Finland and Karelia is a broad, forested zone, varying in width from several hundred meters to tens of kilometers. No human activity is permitted in this area, making it a large nature reserve. The fauna is significantly more diverse in the eastern part of Finland than in the rest of the country. Brown bear density and reproductive success is also highest in the eastern area. Therefore, the border region and adjacent territories are the most suitable habitats for bears, and the majority of the specimens analyzed in this study were collected near the border. The Finnish bear population is characterized by relatively high haplotype diversity (a total of 14 haplotypes were found among 135 samples analyzed), considering the recent demographic bottleneck in the beginning of the 20th century. It is probable that gene flow from Karelia to Finland (and to much lesser extent from Sweden to Finland) explains the relatively high mtDNA diversity. The Karelian bear population has been dense and stable over the last 3 decades and has served as a source for the Finnish population (Danilov 2003); immigration of bears

Table 2. Genetic polymorphism and hypotheses of demographic expansion for 3 subsets of the brown bear population in Finland from data analyzed. $H(n)$ = number of haplotypes; $I(n)$ = number of individuals; Hd = haplotype diversity; π = nucleotide diversity; SD = standard deviation. Statistically significant differences are marked with an *.

Population subset	$H(n)$	$I(n)$	Hd (SD)	π (SD)	Fu and Li's F	Fu's F	Tajima's D
Whole population	14	135	0.55 (0.04)	0.0043 (0.0004)	-2.86 ($P < 0.05$)*	-4.34	-0.94 ($P > 0.10$)
Haplogroup I	7	95	0.16 (0.05)	0.0005 (0.0002)	-3.96 ($P < 0.02$)*	-8.464	-2.04 ($P < 0.05$)*
Haplogroup D	7	40	0.52 (0.09)	0.0022 (0.0004)	-2.08 ($P > 0.05$)	-2.86	-1.05 ($P > 0.1$)

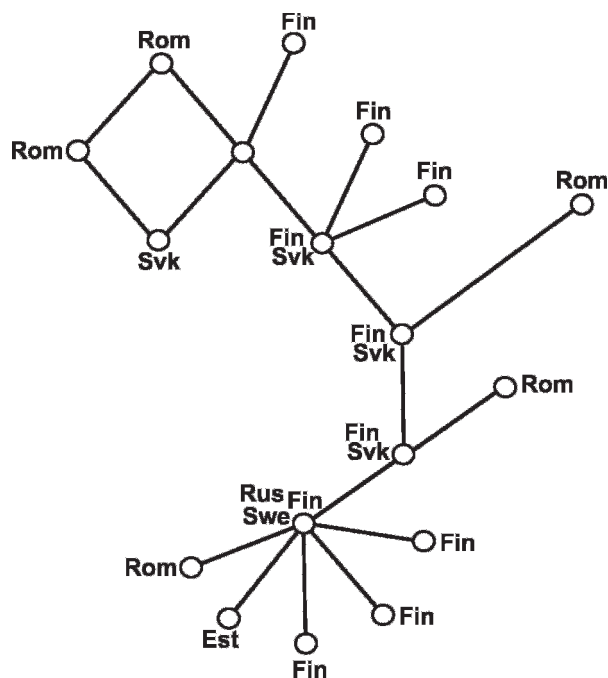

Fig. 5. Schematic mtDNA control region network for brown bears in Europe that belong to the Eastern lineage. Est = Estonia, Fin = Finland, Rom = Romania, Rus = Russia, Svk = Slovakia, Swe = Sweden.

from Karelia has been documented for >35 years (Pulliainen 1990, Kojola et al. 2003).

The distribution of haplotypes (Figs. 2, 3 and Table 2) suggests there may be population substructuring between northern and southern Finland. The southern population seems to include majority of haplotypes from the southern boundaries of the country (all districts south of Oulu and Kainuu). Haplogroup D is presented almost exclusively in southern Finland (with the exception of one individual with haplotype C, sampled at the northern side close to the north–south border). Even the most numerous haplotype of this haplogroup (haplotype D) has been found only in southern districts. Putative northern population (bears of Oulu, Kainuu, and Lappi) includes the remaining haplotypes. Only the haplogroup I appears to be distributed evenly between the northern and southern parts (44 and 51 individuals, respectively). However, mtDNA data represent only the maternal lineage, and further studies, using microsatellites, will be needed to address this question in a more rigorous manner.

Two central and most common haplotypes I and D on the phylogenetic network represent probable ancestral haplotypes. The star-like structures of both haplogroups are also indicators of demographic bottleneck and recent population expansion. However, the hypothesis of recent population expansion received support only for haplogroup I (Table 2).

Most surprising was the concentration of haplotype C in a small territory in central Finland (only a single individual with the haplotype C was recorded in eastern Finland, in the Kuhmo district). This observation was difficult to interpret due to the limited sampling, but there is one possible explanation: during the brown bear reintroduction project from 1982 to 1993, 5 bears (2 females, 3 males) were translocated from eastern Finland to the middle of the country (Nyholm 1995). It is conceivable that at least one translocated female, perhaps the female translocated in 1982, was a carrier of the mitochondrial haplotype C and her descendants are still living close to the home range of their mother. Bears with haplotype C are concentrated in a very small area in the Multia district (total area of 766 km²), and only one bear with this haplotype was found <100 km away, in the Kyyjärvi district. In the Multia district, 3 of the bears analyzed were females and 2 males, whereas the individual sampled in the Kyyjärvi district was male. The high concentration of bears carrying haplotype C into a very small region and the very short dispersal distances of males is consistent with low bear density in this region and a lack of competitive pressure on young males to disperse. Lack of female dispersal is a manifestation of natal philopatry, characteristic to female brown bears. An exception to this pattern occurs when population density approaches saturation (Swenson et al. 1998, Kojola and Laitala 2000).

We examined the relationship of Finnish brown bears to other bear populations that belong to the European eastern clade. The scattering of Finnish haplotypes throughout the genetic network (Fig. 5) can be explained by massive recolonization of brown bears from or through the Romanian–Slovakian region. Alternatively, serial short and long distance recolonization from the east, augmented recently by expansion from the west as well as *de novo* mutations such as those arising in the pyrimidine tract, can also account for the observed pattern.

The future prospects for the Finnish bear population are good. Provided there is enough suitable habitats for the immigrating bears, Finland will

continue to receive additions from both sides: Russian Karelia and Sweden. There are migration corridors for bears through the isthmuses that connect Fennoscandia to the taiga forest in the east. These corridors are important for maintaining connectivity between the subpopulations of many species, including the brown bear. The other neighboring bear population, the Swedish population, is also thriving and has expanded significantly in size and range during recent decades and now consists of approximately 2,200 bears (J. Swenson, personal communication, 2005). The population is divided into 3 subpopulations, as revealed by recent genetic analysis (Manel et al. 2004). Further expansion from the northern subpopulation could eventually reach northern Finland, where the current density of the bear population is low. Genetic analyses of bears in northern Sweden show dissimilarity with those elsewhere in Sweden, suggesting that gene flow might be already taking place across the border (J. Swenson, personal communication, 2005).

Acknowledgments

We thank J. Lind, T. Margus, J. Parik, S. Kilpelä, and A. Väisänen for their generous help. This work was supported by Estonian Science Foundation, grants 4477, 5759; and Estonian Ministry of Education, target financing grants 0181432 and 0182691.

Literature cited

- BANDELT, H.-J., P. FORSTER, AND A. RÖHL. 1999. Median-joining networks for inferring intraspecific phylogenies. *Molecular Biology and Evolution* 16:37–48.
- BENSON, D.A., I. KARSCH-MIZRACHI, D.J. LIPMAN, J. OSTELL, AND D.L. WHEELER. 2007. GenBank. *Nucleic Acids Research* 35:D21–25.
- DANILOV, P. 2003. Status and dynamics of commercial game populations in Karelia. Pages 38–48 in P.I. Danilov and V.B. Zimin, editors. *Dynamics of game animals populations in Northern Europe*. Proceedings of the 3rd International Symposium, Petrozavodsk, Russia.
- GORDON, D., C. ABAJIAN, AND P. GREEN. 1998. CONSED: A graphical tool for sequence finishing. *Genome Research* 8:195–202.
- HALL, T.A. 1999. BIOEDIT: a user friendly biological sequence alignment editor and analysis program for Windows 95/98/NT. *Nucleic Acids Symposium Series* 41:95–98.
- HARPENDING, M.M. 1994. Signature of ancient population growth in a low resolution DNA mismatch distribution. *Human Biology* 66:591–600.
- HEWITT, G. 2000. The genetic legacy of the Quaternary ice ages. *Nature* 405:907–913.
- HOFREITER, M., D. SERRE, N. ROHLAND, G. RABEDER, D. NAGEL, N. CONARD, S. MUNZEL, AND S. PÄÄBO. 2004. Lack of phylogeography in European mammals before the last glaciation. *Proceedings of the National Academy of Sciences* 31:12963–12968.
- KOHN, M., F. KNAUER, A. STOFELLA, W. SCHRÖDER, AND S. PÄÄBO. 1995. Conservation genetics of the brown bear — a study using excremental PCR of nuclear and mitochondrial sequences. *Molecular Ecology* 4:95–103.
- , AND F. KNAUER. 1998. Phylogeography of brown bears in Europe and excremental PCR—the new tool in the genetic analysis of animals in the wild. *Ursus* 10: 315–321.
- KOJOLA, I., AND H.M. LAITALA. 2000. Changes in the structure of an increasing brown bear population with distance from core areas: another example of presaturation female dispersal? *Annales Zoologici Fennici* 37:59–64.
- , P. DANILOV, H.M. LAITALA, V. BELKIN, AND A. YAKIMOV. 2003. Brown bear population structure in core and periphery: analysis of hunting statistics from Russian Karelia and Finland. *Ursus* 14:17–20.
- , AND E. MÄÄTTÄ. 2004. Suomen suurpetojen lukumäärä ja lisääntyminen vuonna 2002. *Riistantutkimuksen tiedote* 202:1–7. (In Finnish.)
- LAMBERT, D.M., P.A. RITCHIE, C.D. MILLAR, B. HOLLAND, A.J. DRUMMOND, AND C. BARONI. 2002. Rates of evolution in ancient DNA from Adélie penguins. *Science* 295:2270–2273.
- MANEL, S., E. BELLEMMAIN, J.E. SWENSON, AND O. FRANCOIS. 2004. Assumed and inferred spatial structure of populations: the Scandinavian brown bears revisited. *Molecular Ecology* 13:1327–31.
- NYHOLM, E.S. 1995. Petosiirrot — riistantutkimuksen vaatimaton kokeilu. *Metsästäjä* 44(1):12–14. (In Finnish.)
- , AND K.E. NYHOLM. 1999. Status of the brown bear in Finland. Pages 63–68 in C. Servheen, S. Herrero, and B. Peyton, editors. *Bears: status survey and conservation action plan*. International Union for the Conservation of Nature and Natural Resources, Gland, Switzerland.
- PALMEN, J.A. 1913. Bär, wolf und luchs in Finland. *Zool. Beobachter* 54:1–6. (In German.)
- PULLIAINEN, E. 1990. Recolonization of Finland by the brown bear in the 1970s and 1980s. *Aquilo Series Zoologica* 27:21–25.
- . 1997. The expansion of brown bears from east into Finland. *International Bear News* 6(3):10–11.
- ROZAS, J., J.C. SANCHEZ-DELBARRIO, X. MESSEGUER, AND R. ROZAS. 2003. DnaSP, DNA polymorphism analyses by the coalescent and other methods. *Bioinformatics* 19:2496–2497.

- SERVHEEN, C. 1990. The status and conservation of the bears of the world. International Conference on Bear Research and Management Monograph 2.
- SHIELDS, F.G., AND T.D. KOCHER. 1991. Phylogenetic relationships of North American ursids based on analysis of mitochondrial DNA. *Evolution* 45:218–221.
- SWENSON, J., F. SANDEGREN, AND A. SÖDERBERG. 1998. Geographic expansion of an increasing brown bear population: evidence for presaturation dispersal. *Journal of Animal Ecology* 67:819–826.
- TABERLET, P., AND J. BOUVET. 1994. Mitochondrial DNA polymorphism, phylogeography, and conservation genetics of the brown bear *Ursus arctos* in Europe. *Proceedings of Royal Society London Series B* 255:195–200.
- , J.E. SWENSON, F. SANDEGREN, AND A. BJÄRVALL. 1995. Localization of contact zone between highly divergent mitochondrial DNA lineages of the brown bear *Ursus arctos* in Scandinavia. *Conservation Biology* 9:1255–1261.
- , L. FUMAGALLI, A.G. WUST-SAUCY, AND J.-C. COSSON. 1998. Comparative phylogeography and post-glacial colonization routes in Europe. *Molecular Ecology* 7:453–464.
- THOMPSON, J.D., D.G. HIGGINS, AND T.J. GIBSON. 1994. CLUSTAL W: improving the sensitivity of progressive multiple sequence alignment through sequence weighting, position specific gap penalties and weight matrix choice. *Nucleic Acid Research* 22:4673–4680.
- VALDMANN, H., U. SAARMA, AND A. KARIS. 2001. The brown bear population in Estonia: current status and requirements for management. *Ursus* 12:31–36.
- ZEDROSSER, A., B. DAHLE, J.E. SWENSON, AND N. GERSTL. 2001. Status and management of the brown bear in Europe. *Ursus* 12:9–20.

Received: 28 October 2005

Accepted: 14 July 2006

Associate Editor: G. Shields